

ASTORIOS

per aspera ad astra

PHOTOVOLTAIC MODULE

**BACK-CONTACT
N-ABC MONO BIFACIAL CELLS**
SILVER FRAME, DOUBLE GLASS

ASTR 132HCNBD/10 Series **650-660 Wp**

660 Wp
MAXIMUM POWER OUTPUT

24.43%
MAXIMUM MODULE EFFICIENCY



BACK-CONTACT

Utilizes back contact technology to enhance light absorption, minimize internal current loss and deliver higher power output



HOT SPOTS RISK REDUCTION

Sophisticated electrical design, cells sorting, cutting and soldering technology leads to low hot spot risk and temperature control



HIGH EFFICIENCY

N-type cells technology provides the highest efficiency modern multi busbar configuration at affordable cost



NEGLIGIBLE LID IMPACT

TOPCon cells exhibit an almost zero susceptibility to Light Induced Degradation, ensuring sustained high efficiency over time despite exposure to sunlight

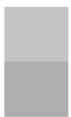

MINIMIZING THE SHADING IMPACT

Better partial-shade tolerance due to separated half panel string wiring



PID RESISTANT

Selected encapsulants, precision in manufacturing quality control makes modules highly PID resistant and snail trails free



SAND, AMMONIA AND SALT MIST RESISTANCE

Sand blowing, ammonia and salt mist resistance tests have been passed by international standards to ensure operation in harsh conditions



SUPERIOR SAFETY AND RELIABILITY

Tested to avoid microcracks and welding cracks, can withstand high pressure loads, passed multi-step quality control

PERFORMANCE

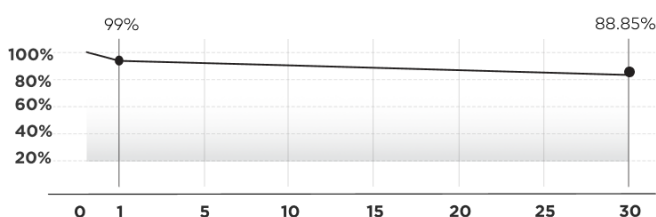

30 YEARS

Performance Guarantee

20 YEARS

Product Warranty

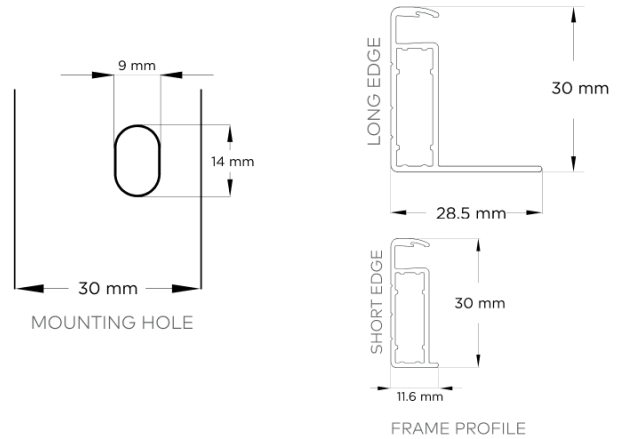
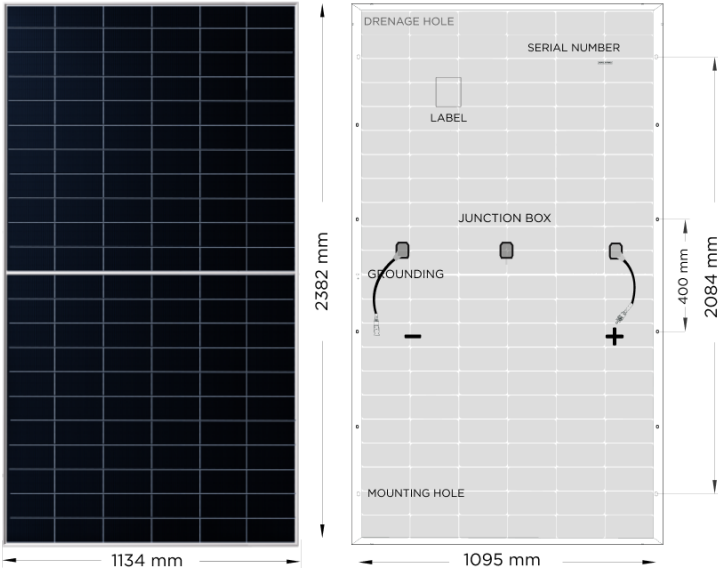

MATERIAL CHARACTERISTICS

Dimensions	2382 x 1134 x 30 mm
Weight	32.5kg
Number of cells	132 pcs (105x182)
Glass	2mm, High transparency, AR coated
Cell layout	Bifacial, N-ABC Mono
Frame	Silver frame, anodized aluminum alloy
Junction box	IP68 Rated, 3 bypass diodes
Connector type	Staubli MC4-Evo 2 / MC4 (Original)
Cable	4 mm ² , 300 mm

TEMPERATURE PARAMETERS

Temperature Coefficient of Pmax	-0.26 % / °C
Temperature Coefficient of Voc	-0.22 % / °C
Temperature Coefficient of Isc	+0.05 % / °C
Operating Temperature	-40°C to +85°C
Normal Operating Cell Temperature (NOCT)	44±2°C

MAXIMUM RATINGS

Max. System Voltage	1500V DC - (H)
Max. Series Fuse Rating	30A
Uplift load (wind)	2400 Pa*
Downforce (snow)	5400 Pa*
Hail Resistance	25mm ice-ball with velocity of 23m/s

*For more information please refer to Instruction Manual

PACKAGING INFORMATION

One pallet quantity	36 Pcs / 1190kg / 1160x1130x2535mm
40 ft HC/HQ container	720 Pcs / 36 Pallets

MODULE TYPE 132HCNBD/10	650 Wp		655 Wp		660 Wp	
	STC	NMOT	STC	NMOT	STC	NMOT
Maximum power (Pmax/Wp)	650	499	655	503	660	507
Open circuit voltage (Voc / V)	49.85	47.65	50.03	47.83	50.20	47.99
Short circuit current (Isc / A)	16.17	13.04	16.22	13.08	16.27	13.12
Maximum power voltage (Vmp / V)	42.74	40.35	42.90	40.51	43.06	40.67
Maximum power current (Imp / A)	15.21	12.37	15.27	12.42	15.33	12.47
Module efficiency at STC (ηm / %)	24.06		24.25		24.43	
Power tolerance (Pmax)			0-+3%			

NMOT: Irradiance 800 W/m², ambient temperature 20°C, wind speed 1 m/s / **STC:** Irradiance of 1000 W/m², spectrum AM 1.5, a module temperature of 25°C

CERTIFICATES

IEC62716 (Ammonia)
IEC60068-2-68 (Sand)
IEC61215 / 61730 / 61701



I-V Curve at Different Temperature (655 W)

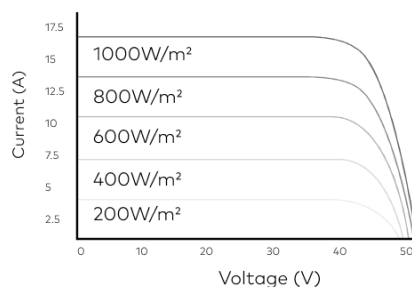

P-V Curve

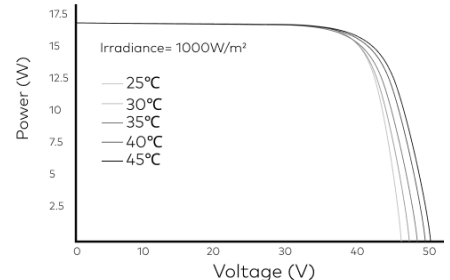

ASTORIOS Holding Inc.
16192 Coastal Highway, Lewes,
Delaware 19958, USA
info@astorios.com